

# Wireless Transparent Modules Datasheet

## 32001540

DUAL MODE 868 MHz TRANSCEIVER

## Datasheet

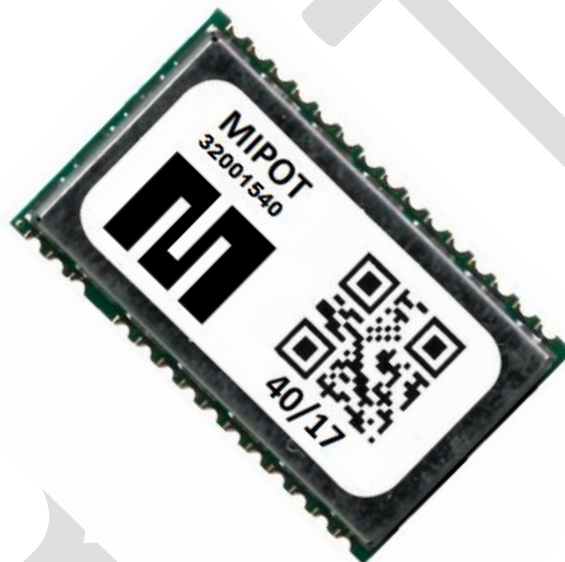

### Overview

Dual-mode transceiver operating in the 868 MHz SRD band with extremely compact dimensions. The module operates as an independent device that can be controlled through external control lines.

# Contents

1. Product Features .....	3
2. Mechanical Dimensions .....	4
3. Pin Definition .....	5
4. Electrical Characteristics .....	6
4.1. Absolute Maximum Ratings .....	6
4.2. Operating Condition .....	6
4.2.1. Notes: .....	9
5. Temperature Range Curves .....	10
5.1. Receiver .....	10
5.2. Transmitter .....	11
6. Application Notes .....	12
6.1. Standard Mode .....	12
6.1.1. Control via UART .....	12
6.1.2. Control via GPIO .....	13
6.2. Extended Mode .....	14
7. Recommended Module PCB Footprint .....	15
8. Application Notes .....	16
9. Regulatory Approvals .....	16
10. Revision History .....	16

## I. Product Features

### Mechanical highlights:

- ✓ Compact dimensions

### RF performances:

- ✓ -102 dBm FSK Sensitivity
- ✓ -101 dBm OOK Sensitivity
- ✓ +10 dBm Output power
- ✓ Category 1.5 Receiver

### Low power characteristics:

- ✓ Sleep current consumption 50 nA

### Additional features:

- ✓ Configurable RF parameters

Two operating modes available on the device:

**Normal mode:** The TRX module operates as a dual channel (868.15 - 868.45 MHz) OOK transceiver. Through the external pins, the user can control the operation mode (TX, RX, Sleep Mode) and the channel frequency.

**Extended Mode:** Through a predefined sequence of serial commands sent to the module, the user can customize it. Configurable parameters are the output power, the channel frequency, OOK mode, an advanced low-power mode and data rate up to 38400 bit/s.

Standard supply voltage range from 2.1 to 3.6 V. The module meets all the requirements in the industrial temperature range -40 / +85 °C.

**CATEGORY 1.5 RECEIVER** developed according to ETSI EN 300 220 European Standard. The module meets the Radio Equipment Directive (RED) 2014/53/EU. Compliant with REACH and RoHS directives.

## 2. Mechanical Dimensions

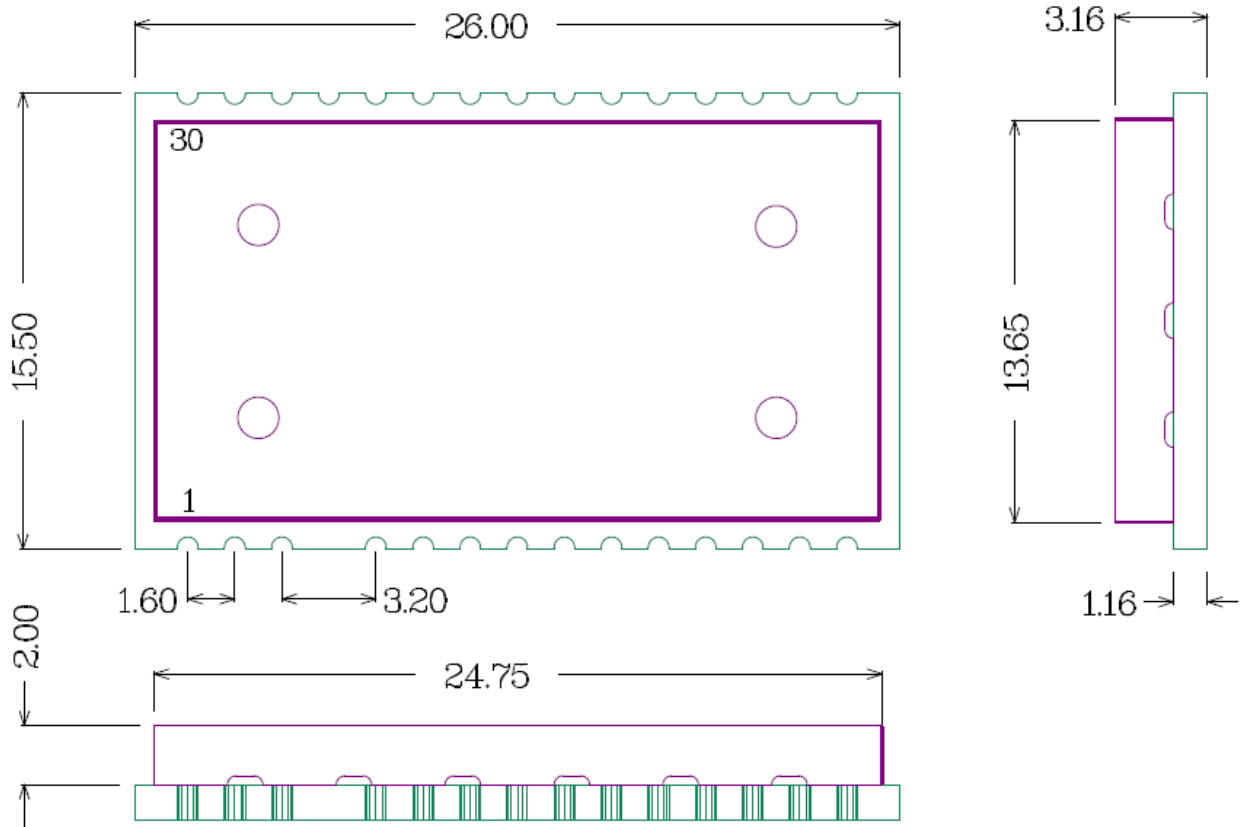

ALL DIMENSIONS ARE IN MILLIMETERS

GENERAL TOLERANCE +/-0.1MM

### 3. Pin Definition

Pin	Name	Type
1	GND	S
2	RF I/O	RF
3	GND	S
5	DATA IN	I
6	NC	NC
7	NC	NC
8	NC	NC
9	NC	NC
10	NC	NC
11	NC	NC
12	NC	NC
13	NC	NC
14	NC	NC
15	GND	S
16	GND	S
17	VDD	S
18	NC	NC
19	NC	NC
20	NC	NC
21	NC	NC
22	TX/RX	I/O
23	DATA OUT	O
24	EN	I
25	CHSEL	I
26	NC	NC
27	NC	NC
28	NC	NC
29	NC	NC
30	GND	S

**LEGEND:** S = Power supply, O = Output, I = Input, RF = Antenna port, NC = Do Not Connect

## 4. Electrical Characteristics

### 4.1. Absolute Maximum Ratings

Parameter	Max.	Unit
Supply Voltage (VDD)	3.9	V
Max voltage on pins 4, 5, 6, 8, 9	VDD + 0.3	V
Storage Temperature	-40 to 100	°C
Operating Temperature	-40 to 85	°C
Radio Frequency Input, pin 2	10	dBm

### 4.2. Operating Condition

**Note:** All RF parameters measured with input (pin 1) connected to a 50  $\Omega$  impedance signal source or load.

GENERAL ELECTRICAL CHARACTERISTICS @ 25 °C
--

Parameter	Min.	Typ.	Max.	Unit	Notes
Supply Voltage (VDD)	2.1	3.0	3.6	V	
TX Current consumption	-	-	25	mA	1
RX Current consumption	-	-	15	mA	2
Sleep Mode Current consumption	-	3	-	$\mu$ A	10
Operating Band	868.0	-	868.6	MHz	
Operating frequency Channel 1	-	868.15	-	MHz	5, 6
Operating frequency Channel 2	-	868.45	-	MHz	5, 6
Operating Channel Width	-	200	-	kHz	
2-FSK deviation	-	25	-	kHz	6
Data Rate	-	9600	-	bit/s	6
V <sub>low</sub> on I/O pins	0	-	0.3xVDD	V	
V <sub>high</sub> on I/O pins	0.7xVDD	-	VDD	V	
Output load on pin 4	2	-	-	k $\Omega$	

RECEIVER ELECTRICAL CHARACTERISTICS @ 25 °C

Parameter	Min.	Typ.	Max.	Unit	Notes
FSK Sensitivity	-	-102	-	dBm	3
OOK Sensitivity	-	-101	-	dBm	4
2-FSK -3 dB RF Bandwidth	-	100	-	kHz	3
OOK -3 dB RF Bandwidth	-	100	-	kHz	4
Blocking	-30	-	-	dBm	7
Unwanted spurious emission	-	-	-58	dBm	8

TRANSMITTER ELECTRICAL CHARACTERISTICS @ 25 °C

Parameter	Min.	Typ.	Max.	Unit	Notes
Output Power	-	10	-	dBm	
2-FSK Occupied Bandwidth	-	70	-	kHz	
OOK Occupied Bandwidth	-	100	-	kHz	
Unwanted spurious emission	-	-	-36	dBm	8
Out-of-band emissions	-	-	-36	dBm	9
Frequency accuracy	-	25	-	ppm	

OOK TIMINGS @ 25 °C @ VDD = 3.0 V

Parameter	Min.	Typ.	Max.	Unit	Notes
Time between power on and valid data reception	-	40	-	ms	
Time between power on and valid data transmission	-	40	-	ms	
Time by Sleep Mode to RX	-	1.5	-	ms	
Time by Sleep Mode to TX	-	1.5	-	ms	
Time by TX to RX	-	800	-	µs	
Time by RX to TX	-	800	-	µs	
RX Time by CH1 to CH2	-	1	-	ms	
RX Time by CH2 to CH1	-	1	-	ms	
TX Time by CH1 to CH2	-	1	-	ms	
TX Time by CH2 to CH1	-	1	-	ms	

FSK TIMINGS @ 25 °C @ VDD = 3.0 V

Parameter	Min.	Typ.	Max.	Unit	Notes
Time between power on and valid data reception	-	40	-	ms	
Time between power on and valid data transmission	-	40	-	ms	
Time by Sleep Mode to RX	-	1.5	-	ms	
Time by Sleep Mode to TX	-	1.5	-	ms	
Time by TX to RX	-	800	-	µs	
Time by RX to TX	-	800	-	µs	
RX Time by CH1 to CH2	-	1	-	ms	
RX Time by CH2 to CH1	-	1	-	ms	
TX Time by CH1 to CH2	-	1	-	ms	
TX Time by CH2 to CH1	-	1	-	ms	



#### 4.2.1. Notes:

- Note 1:** TX Current consumption measured with CW carrier @ maximum power output.
- Note 2:** RX Current consumption measured with pseudo-random bit sequence code demodulated, 9600 bit/s, BER  $\leq 10^{-3}$ .
- Note 3:** Test signal 2-FSK pseudo-random bit sequence code NRZ (dev.  $\pm 25$  kHz) 9600 bit/s. Results @ BER  $\leq 10^{-3}$ .
- Note 4:** Test signal OOK pseudo-random bit sequence code NRZ (mod. 100%) 9600 bit/s. Results @ BER  $\leq 10^{-3}$ .
- Note 5:** The frequency values described are the default ones. Each channel is configurable between the following frequencies: 868.100 MHz, 868.150 MHz, 868.200 MHz, 868.300 MHz, 868.400 MHz, 868.450 MHz, 868.500 MHz, 868.825 MHz, 868.950 MHz, 869.075 MHz, 869.850 MHz. For further information see the document **32001535\_Command\_Reference.pdf**.
- Note 6:** Programmable parameters in Extended Mode. For further information see the document **32001535\_Command\_Reference.pdf**.
- Note 7:** Measured as per ETSI 300 220-1, 5.18 "Blocking".
- Note 8:** Measured as per ETSI 300 220-1, "Unwanted emissions in the spurious domain", 5.9.1.1 "Unwanted emissions for TX mode" and 5.9.1.2 "Unwanted emissions for all other modes".
- Note 9:** Measured as per ETSI 300 220-1, 5.8 "Tx Out of Band Emissions".
- Note 10:** Current consumption can be decreased up to 50 nA. For further information see the document **32001535\_Command\_Reference.pdf**.

## 5. Temperature Range Curves

**Note:** All RF parameters measured with input (pin 1) connected to a 50  $\Omega$  impedance signal source or load.

### 5.1. Receiver

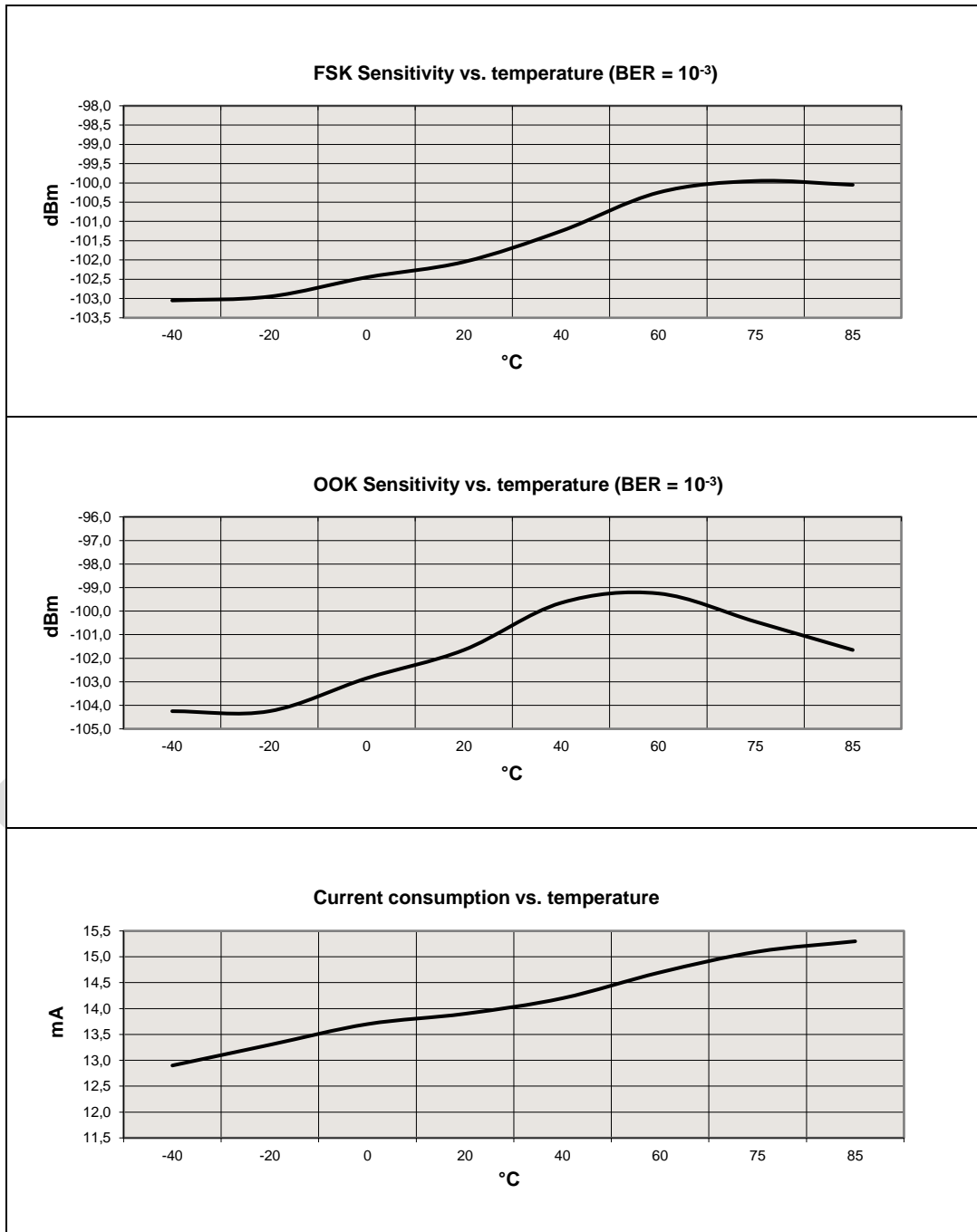

## 5.2. Transmitter

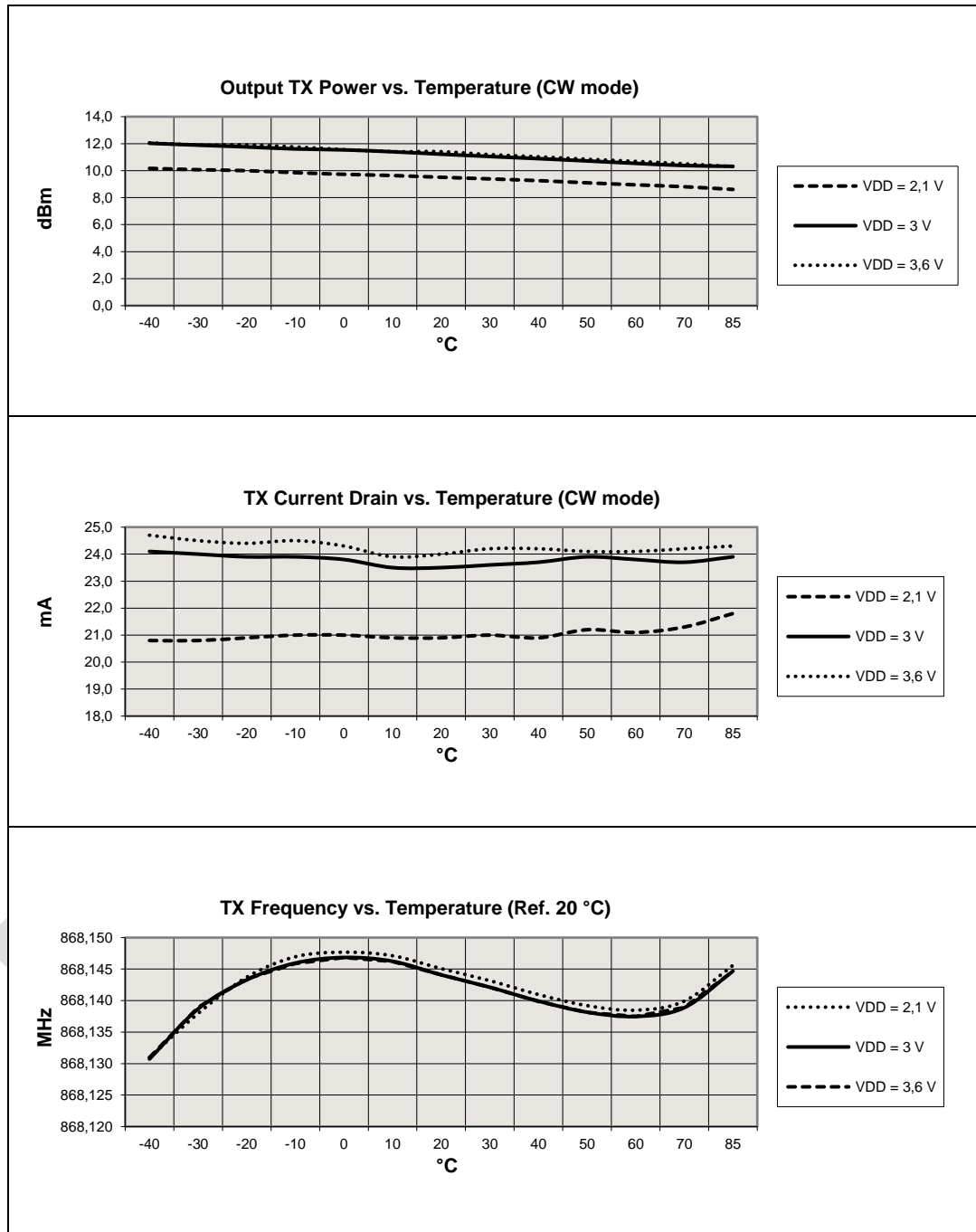

## 6. Application Notes

### 6.1. Standard Mode

The default mode behaves as a transparent device with respect to the data stream.

#### 6.1.1. Control via UART

DATA IN and DATA OUT pins of the transceiver are connected to the UART communication peripheral of the microcontroller.

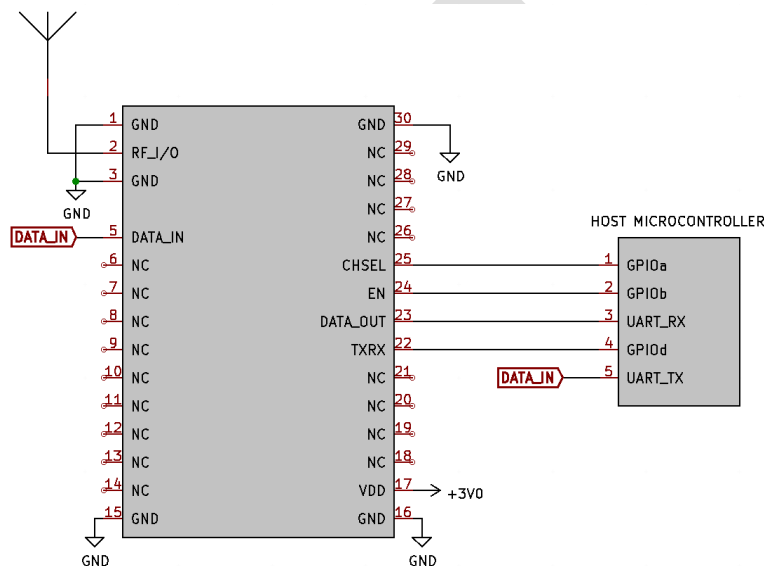

In this mode the control pins on the microcontroller side must be configured as follow:

Pin	Pin name	Configuration	Control
1	GPIOa	DIGITAL OUTPUT	Channel selection pin. <ul style="list-style-type: none"> <li>0: module operating on channel 1 (868.15 MHz)</li> <li>1: module operating on channel 2 (868.45 MHz)</li> </ul>
2	GPIOb	DIGITAL OUTPUT	Enable pin. Allow to activate or set in Sleep Mode the module, according to the following logic: <ul style="list-style-type: none"> <li>0: power down (module in Sleep Mode)</li> <li>1: enable (module operative)</li> </ul>
3	UART_RX	UART data RX	RX data stream to the host microcontroller.
4	GPIOd	DIGITAL OUTPUT	Operating mode selection pin. <ul style="list-style-type: none"> <li>0: module in reception (RX mode)</li> <li>1: module in transmission (TX mode)</li> </ul>
5	UART_TX	UART data TX	TX data stream to the radio module

### 6.1.2. Control via GPIO

DATA IN and DATA OUT pins of the module are sampled with the host microcontroller general purpose input-output peripheral.

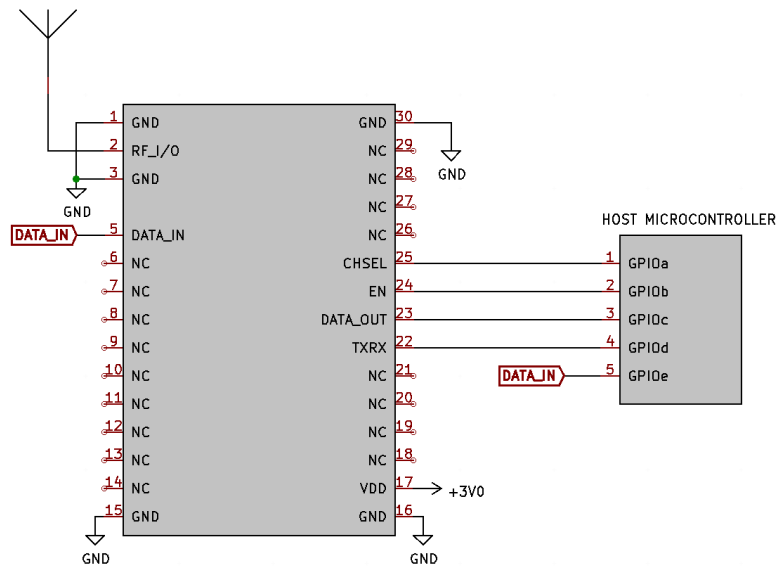

In this mode the control pins on the microcontroller side must be configured as follow:

Pin	Pin name	Configuration	Control
1	GPIOa	DIGITAL OUTPUT	Channel selection pin. <ul style="list-style-type: none"> <li>0: module operating on channel 1 (868.15 MHz)</li> <li>1: module operating on channel 2 (868.45 MHz)</li> </ul>
2	GPIOb	DIGITAL OUTPUT	Enable pin. Allow to activate or set in Sleep Mode the module, according to the following logic: <ul style="list-style-type: none"> <li>0: power down (module in Sleep Mode)</li> <li>1: enable (module operative)</li> </ul>
3	GPIOc	DIGITAL INPUT	RX data stream to the host microcontroller.
4	GPIOd	DIGITAL OUTPUT	Operating mode selection pin. <ul style="list-style-type: none"> <li>0: module in reception (RX mode)</li> <li>1: module in transmission (TX mode)</li> </ul>
5	GPIOe	DIGITAL OUTPUT	TX data stream to the radio module

## 6.2. Extended Mode

In Extended Mode, user can enter various configuration and then customize the module. The following radio parameters can be changed:

### Power level:

- +10 dBm (Default)
- +7 dBm
- +4 dBm
- +1 dBm
- -2 dBm
- -5 dBm

### Modulation:

- 2-FSK (Default)
- OOK

### Shutdown mode:

- 50 nA of current consumption

### Channel frequency:

- 868.100 MHz
- 868.150 MHz (Default for Channel 1)
- 868.200 MHz
- 868.300 MHz
- 868.400 MHz
- 868.450 MHz (Default for Channel 2)
- 868.500 MHz
- 868.825 MHz
- 868.950 MHz
- 869.075 MHz
- 869.850 MHz

### Synchronizer:

- Sync disabled, normal mode, data transparent (Default)
- Sync disabled, “slow” mode
- Sync enabled, 1200 bit/s
- Sync enabled, 2400 bit/s
- Sync enabled, 4800 bit/s
- Sync enabled, 9600 bit/s (Default)

In addition to the standard configuration, for the extended use, the control pins on microcontroller side must have the following capabilities,:

Pin	Pin name	Configuration	Control
3	GPIOc	DIGITAL INPUT INTERNAL PULL UP	Extended Mode operation: Module is capable of returning a feedback in case of successful programming. For a detailed description how to implement it, see the application note <b><a href="#">32001535_Command_Reference.pdf</a></b> .
4	GPIOd	UART TX DIGITAL INPUT DIGITAL OUTPUT	Extended Mode operation: Host microcontroller sends data frames to setup the transceiver. For a detailed description how to implement it, see the application note <b><a href="#">32001535_Command_Reference.pdf</a></b> .

## 7. Recommended Module PCB Footprint

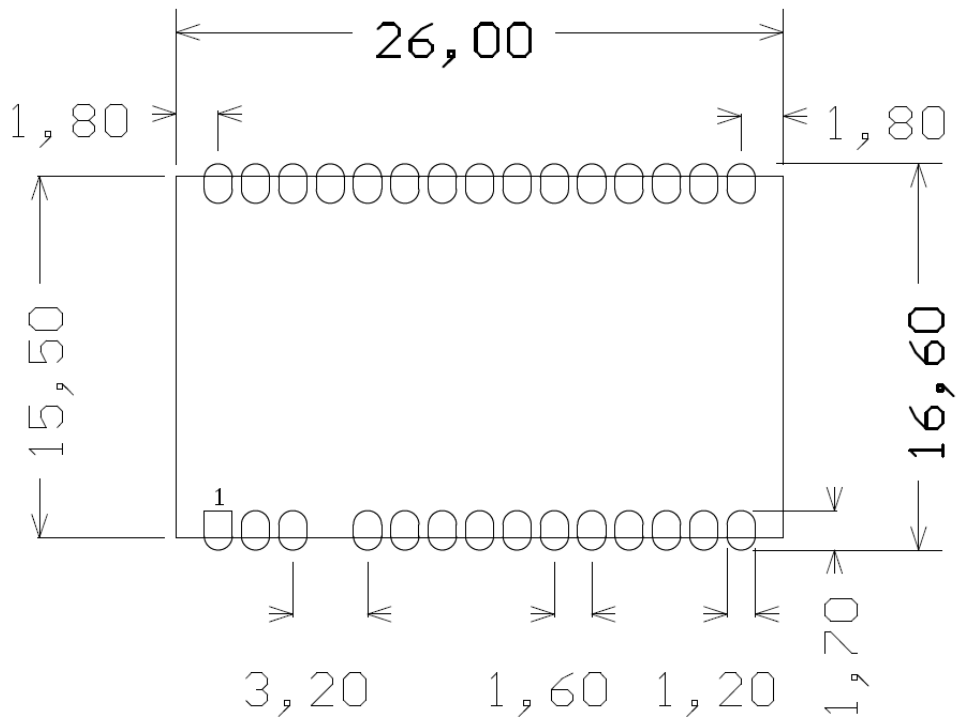

NOTE: ALL DIMENSIONS ARE IN MILLIMETERS

## 8. Application Notes

Title	Description	Doc
Command Reference Manual	Description of all commands	32001535_Command_Reference.pdf
PCB Layout Guidelines	Hints how to make for a good RF design	AN_RF_001.pdf

## 9. Regulatory Approvals

Doc	Title	Description
-	Declaration of Conformity	Declaration of the conformity with the essential requirements of the European Directive 2014/53/EU

## 10. Revision History

Revision	Date	Description
0.0	27.07.2022	Draft