

Wireless Transparent Modules Datasheet

32001539

DUAL MODE 434 MHz TRANSCEIVER

Datasheet

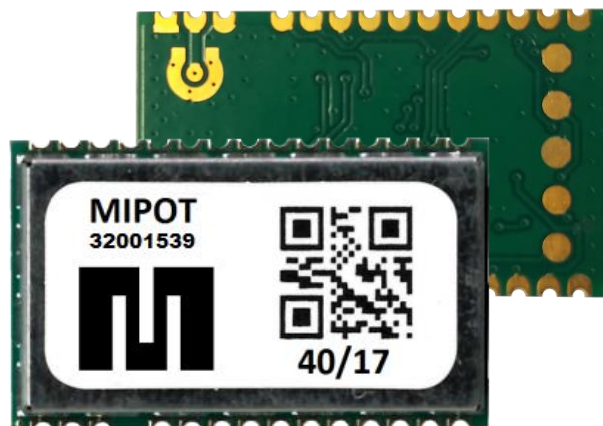

Overview

Dual-mode transceiver operating in the 434 MHz SRD band with extremely compact dimensions. The module operates as an independent device that can be controlled through external control lines.

Contents

1. Product Features	3
2. Mechanical Dimensions	4
3. Pin Definition	5
4. Electrical Characteristics	6
4.1. Absolute Maximum Ratings	6
4.2. Operating Condition	6
4.2.1. Notes:	9
5. Temperature Range Curves	10
5.1. Receiver	10
5.2. Transmitter	11
6. I/O Pins Status and Control	12
6.1. Standard Mode	12
6.1.1. Control via UART	12
6.1.2. Control via GPIO	13
6.2. Extended Mode	14
7. Recommended Module PCB Footprint	15
8. Application Notes	16
9. Regulatory Approvals	16
10. Revision History	16

I. Product Features

Mechanical highlights:

- ✓ Compact dimensions
(26 mm x 15.50 mm)

RF performances:

- ✓ -105 dBm Sensitivity in FSK
- ✓ -107 dBm Sensitivity in OOK
- ✓ 10 dBm Output power
- ✓ Category 1.5 Receiver

Low power characteristics:

- ✓ Sleep current consumption 50 nA

Additional features:

- ✓ Configurable RF parameters

Two operating modes available on the device:

Normal mode: The TRX module operates as a dual channel (433.42 - 434.42 MHz) OOK transceiver. Through the external pins, the user can control the operation mode (TX, RX, Sleep Mode) and the channel frequency.

Extended Mode: Through a predefined sequence of serial commands sent on the module, the user can customize it. Configurable parameters are the output power, the channel frequency, 2-FSK mode, an advanced low-power mode and data rate up to 4800 bit/s.

Standard supply voltage range from 2.1 to 3.6 V. The module meets all the requirements in the industrial temperature range -40 / +85 °C.

CATEGORY 1.5 RECEIVER developed according to ETSI EN 300 220 European Standard. The module meets the Radio Equipment Directive (RED) 2914/53/EU. Compliant with REACH and RoHS directives.

2. Mechanical Dimensions

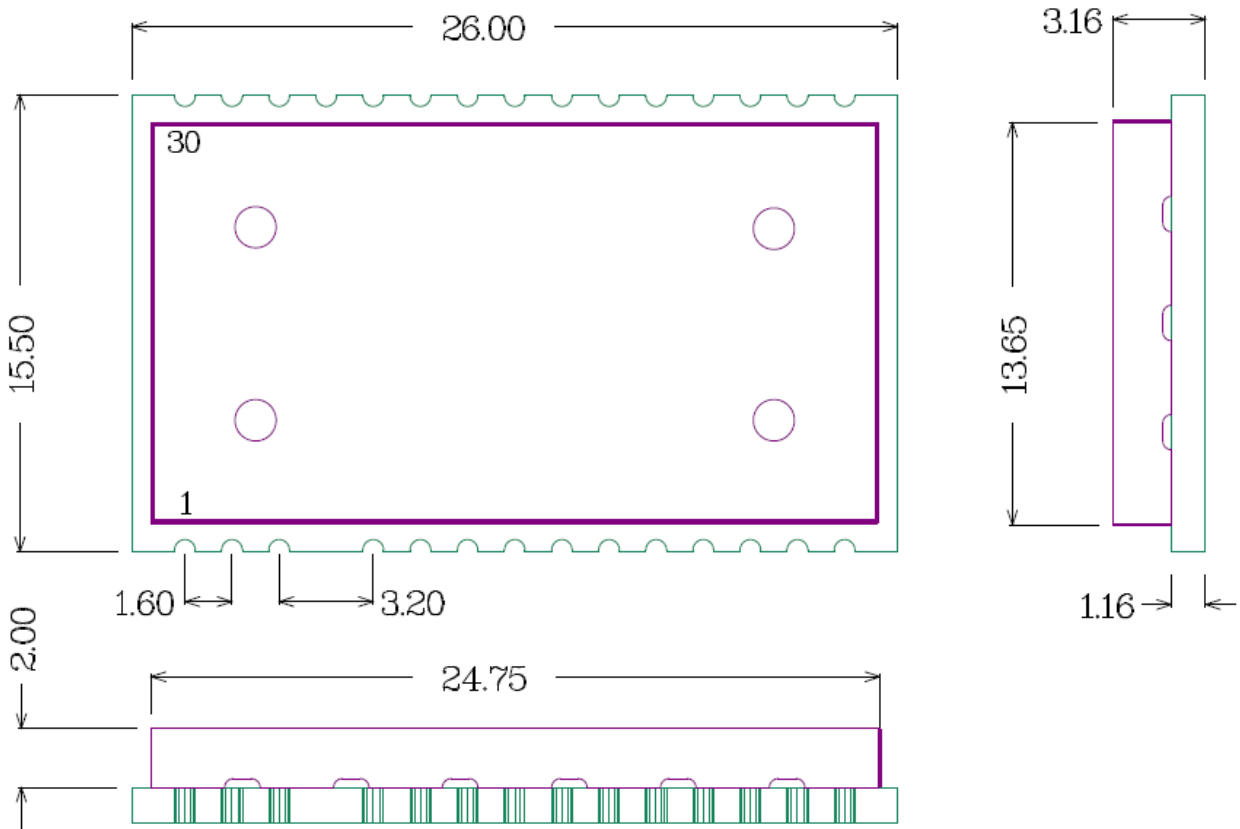

ALL DIMENSIONS ARE IN MILLIMETERS

GENERAL TOLERANCE ± 0.1 MM

3. Pin Definition

Pin	Name	Type
1	GND	S
2	RF I/O	RF
3	GND	S
5	DATA IN	I
6	NC	NC
7	NC	NC
8	NC	NC
9	NC	NC
10	NC	NC
11	NC	NC
12	NC	NC
13	NC	NC
14	NC	NC
15	GND	S
16	GND	S
17	VDD	S
18	NC	NC
19	NC	NC
20	NC	NC
21	NC	NC
22	TX/RX	I/O
23	DATA OUT	O
24	EN	I
25	CHSEL	I
26	NC	NC
27	NC	NC
28	NC	NC
29	NC	NC
30	GND	S

LEGEND: S = Power supply, O = Output, I = Input, RF = Antenna port, NC = Do Not Connect

4. Electrical Characteristics

4.1. Absolute Maximum Ratings

Parameter	Max.	Unit
Supply Voltage (VDD)	3.9	V
Max voltage on pins 4, 5, 6, 8, 9	VDD + 0.3	V
Storage Temperature	-40 to 100	°C
Operating Temperature	-40 to 85	°C
Radio Frequency Input, pin 2	10	dBm

4.2. Operating Condition

Note: All RF parameters measured with input (pin 1) connected to a 50 Ω impedance signal source or load.

GENERAL ELECTRICAL CHARACTERISTICS @ 25 °C
--

Parameter	Min.	Typ.	Max.	Unit	Notes
Supply Voltage (VDD)	2.1	3.0	3.6	V	
Sleep Mode Current consumption	-	3	-	μ A	10
Operating Band	433.05	-	434.79	MHz	
Operating frequency Channel 1	-	433.42	-	MHz	5
Operating frequency Channel 2	-	434.42	-	MHz	5
Operating Channel Width	-	200	-	kHz	
2-FSK deviation	-	\pm 25	-	kHz	6
Data Rate	1200	-	4800	bit/s	6
V _{low} on I/O pins	0	-	0.3xVDD	V	
V _{high} on I/O pins	0.7xVDD	-	VDD	V	
Output load on pin 23	2	-	-	k Ω	

RECEIVER ELECTRICAL CHARACTERISTICS @ 25 °C

Parameter	Min.	Typ.	Max.	Unit	Notes
RX Current consumption	-	14	17	mA	2
OOK Sensitivity	-	-107		dBm	3
FSK Sensitivity	-	-105	-	dBm	4
OOK -3 dB RF Bandwidth	-	200	-	kHz	3
2-FSK -3 dB RF Bandwidth	-	50	-	kHz	4
Blocking	-	-27	-	dBm	7
Unwanted spurious emission	-	-	-58	dBm	8

TRANSMITTER ELECTRICAL CHARACTERISTICS @ 25 °C

Parameter	Min.	Typ.	Max.	Unit	Notes
TX Current consumption	-	20	26.5	mA	1
Output Power	-	10	-	dBm	6
OOK Occupied Bandwidth	-	42	-	kHz	
2-FSK Occupied Bandwidth	-	62	-	kHz	
Unwanted spurious emission	-	-	-41	dBm	8
Out-of-band emissions	-	-	-36	dBm	9
Frequency accuracy	-	-	15	ppm	

OOK TIMINGS @ 25 °C @ VDD = 3.0 V

Parameter	Min.	Typ.	Max.	Unit	Notes
Time between power on and valid data reception	-	40	-	ms	
Time between power on and valid data transmission	-	40	-	ms	
Time by Sleep Mode to RX	-	1.5	-	ms	
Time by Sleep Mode to TX	-	1.5	-	ms	
Time by TX to RX	-	800	-	µs	
Time by RX to TX	-	800	-	µs	
RX Time by CH1 to CH2	-	1	-	ms	
RX Time by CH2 to CH1	-	1	-	ms	
TX Time by CH1 to CH2	-	1	-	ms	
TX Time by CH2 to CH1	-	1	-	ms	

2-FSK TIMINGS @ 25 °C @ VDD = 3.0 V

Parameter	Min.	Typ.	Max.	Unit	Notes
Time between power on and valid data reception	-	40	-	ms	
Time between power on and valid data transmission	-	40	-	ms	
Time by Sleep Mode to RX	-	1.5	-	ms	
Time by Sleep Mode to TX	-	1.5	-	ms	
Time by TX to RX	-	800	-	µs	
Time by RX to TX	-	800	-	µs	
RX Time by CH1 to CH2	-	1	-	ms	
RX Time by CH2 to CH1	-	1	-	ms	
TX Time by CH1 to CH2	-	1	-	ms	
TX Time by CH2 to CH1	-	1	-	ms	

4.2.1. Notes:

- Note 1:** TX Current consumption measured with CW carrier @ 10dBm.
- Note 2:** RX Current consumption measured with pseudo-random bit sequence code demodulated, 4800 bit/s, BER $\leq 10^{-3}$.
- Note 3:** Test signal OOK pseudo-random bit sequence code NRZ (mod. depth 100%) 4800 bit/s. Results @ BER $\leq 10^{-3}$.
- Note 4:** Test signal 2-FSK pseudo-random bit sequence code NRZ (dev. ± 25 kHz) 4800 bit/s. Results @ BER $\leq 10^{-3}$.
- Note 5:** The frequency values described are the default ones. Each channel is configurable between the following frequencies: 433.20 MHz, 433.42 MHz, 433.92 MHz, 434.42 MHz, 434.64 MHz. For further information see the document **32001539_Command_Reference.pdf**.
- Note 6:** Programmable parameters in Extended Mode. For further information see the document **32001539_Command_Reference.pdf**.
- Note 7:** Measured as per ETSI 300 220-1, 5.18 “Blocking”.
- Note 8:** Measured as per ETSI 300 220-1, “Unwanted emissions in the spurious domain”, 5.9.1.1 “Unwanted emissions for TX mode” and 5.9.1.2 “Unwanted emissions for all other modes”.
- Note 9:** Measured as per ETSI 300 220-1, 5.8 “Tx Out of Band Emissions”.
- Note 10:** Current consumption can be decreased up to 50 nA. For further information see the document **32001539_Command_Reference.pdf**.

5. Temperature Range Curves

Note: All RF parameters measured with input (pin 1) connected to a 50 Ω impedance signal source or load.

5.1. Receiver

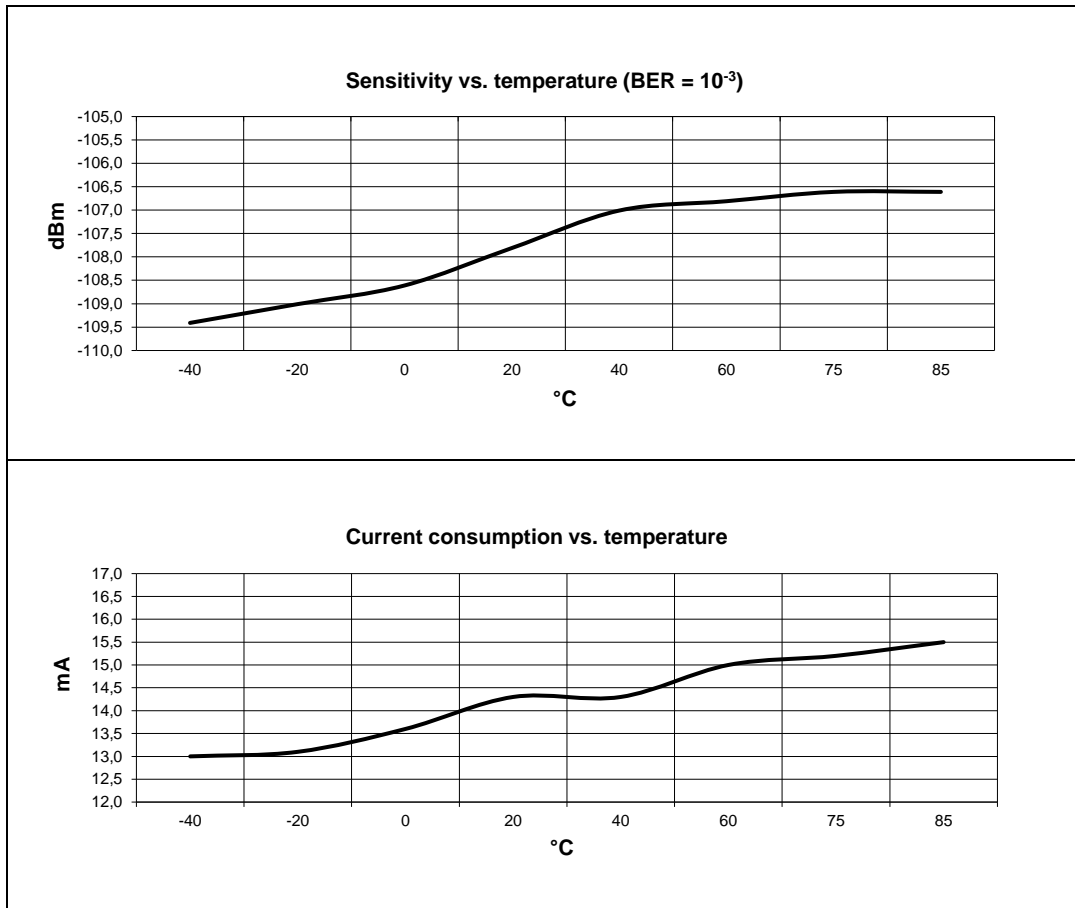

5.2. Transmitter

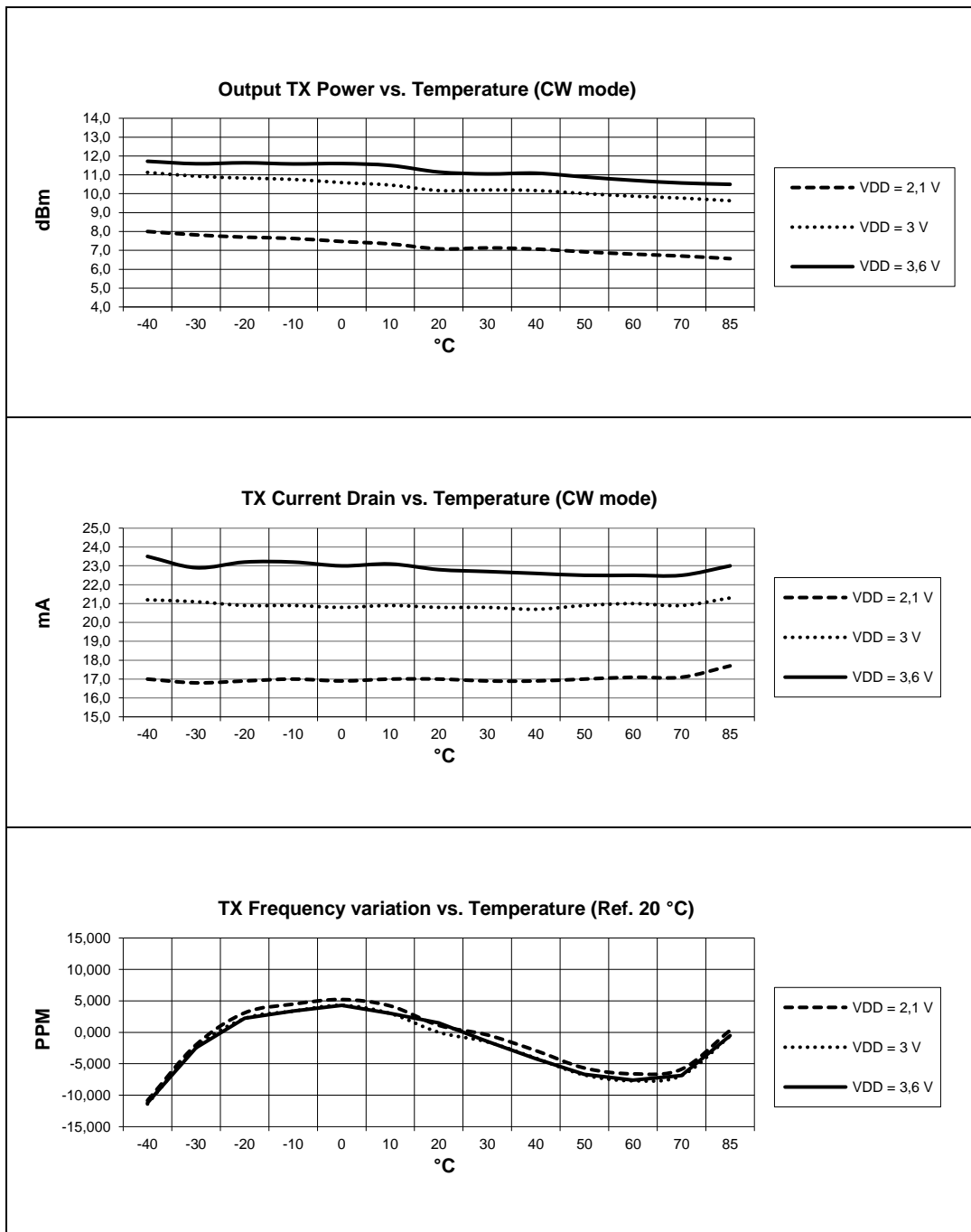

6. I/O Pins Status and Control

6.1. Standard Mode

The default mode behaves as a transparent device with respect to the data stream.

6.1.1. Control via UART

DATA IN and DATA OUT pins of the transceiver are connected to the UART communication peripheral of the microcontroller.

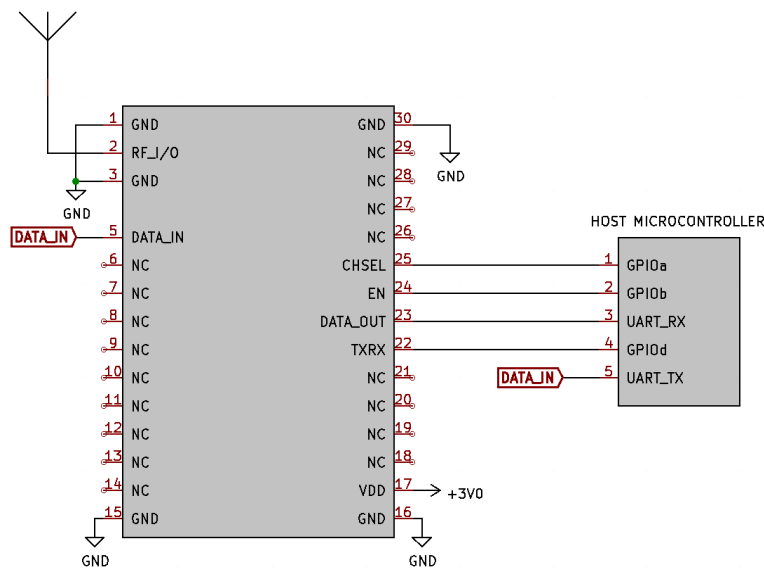

In this mode the control pins on the microcontroller side must be configured as follow:

Pin	Pin name	Configuration	Control
1	GPIOa	DIGITAL OUTPUT	Channel selection pin. <ul style="list-style-type: none"> 0: module operating on channel 1 (433.42 MHz) 1: module operating on channel 2 (434.42 MHz)
2	GPIOb	DIGITAL OUTPUT	Enable pin. Allow to activate or set in Sleep Mode the module, according to the following logic: <ul style="list-style-type: none"> 0: power down (module in Sleep Mode) 1: enable (module operative)
3	UART_RX	UART data RX	RX data stream to the host microcontroller.
4	GPIOd	DIGITAL OUTPUT	Operating mode selection pin. <ul style="list-style-type: none"> 0: module in reception (RX mode) 1: module in transmission (TX mode)
5	UART_TX	UART data TX	TX data stream to the radio module

6.1.2. Control via GPIO

DATA IN and DATA OUT pins of the module are sampled with the host microcontroller general purpose input-output peripheral.

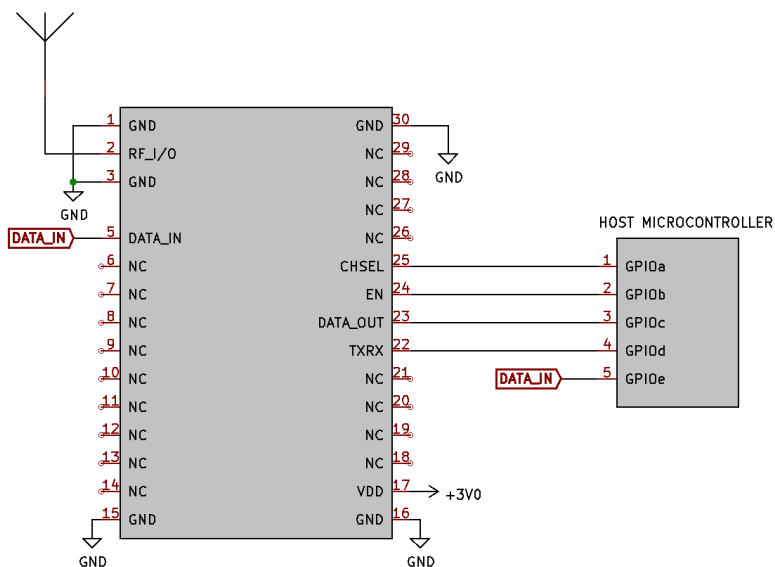

In this mode the control pins on the microcontroller side must be configured as follow:

Pin	Pin name	Configuration	Control
1	GPIOa	DIGITAL OUTPUT	Channel selection pin. <ul style="list-style-type: none"> 0: module operating on channel 1 (433.42 MHz) 1: module operating on channel 2 (434.43 MHz)
2	GPIOb	DIGITAL OUTPUT	Enable pin. Allow to activate or set in Sleep Mode the module, according to the following logic: <ul style="list-style-type: none"> 0: power down (module in Sleep Mode) 1: enable (module operative)
3	GPIOc	DIGITAL INPUT	RX data stream to the host microcontroller.
4	GPIOd	DIGITAL OUTPUT	Operating mode selection pin. <ul style="list-style-type: none"> 0: module in reception (RX mode) 1: module in transmission (TX mode)
5	GPIOe	DIGITAL OUTPUT	TX data stream to the radio module

6.2. Extended Mode

In Extended Mode, user can enter various configuration and then customize the module. The following radio parameters can be changed:

Power level:

- +10 dBm (Default)
- +7 dBm
- +4 dBm
- +1 dBm
- -2 dBm
- -5 dBm

Modulation:

- OOK (Default)
- 2-FSK

Shutdown mode:

- 50 nA of current consumption

Channel frequency:

- 433.42 MHz (Default for Channel 1)
- 433.92 MHz
- 434.42 MHz (Default for Channel 2)
- 433.20 MHz
- 434.64 MHz

Synchronizer:

- Sync disabled, normal mode, data transparent (Default)
- Sync disabled, “slow” mode
- Sync enabled, 1200 bit/s
- Sync enabled, 2400 bit/s
- Sync enabled, 4800 bit/s

In addition to the standard configuration, for the extended use, the control pins on microcontroller side must have the following capabilities,:

Pin	Pin name	Configuration	Control
3	GPIOc	DIGITAL INPUT INTERNAL PULL UP	Extended Mode operation: Module is capable of returning a feedback in case of successful programming. For a detailed description how to implement it, see the application note 32001539_Command_Reference.pdf .
4	GPIOd	UART TX DIGITAL INPUT DIGITAL OUTPUT	Extended Mode operation: Host microcontroller sends data frames to setup the transceiver. For a detailed description how to implement it, see the application note 32001539_Command_Reference.pdf .

7. Recommended Module PCB Footprint

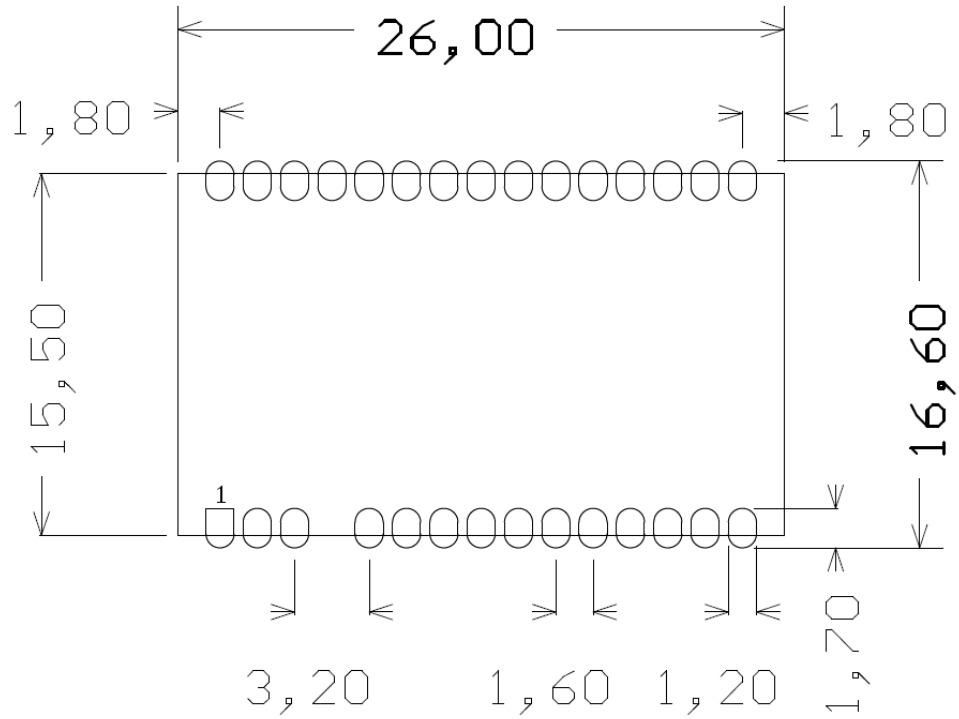

NOTE: ALL DIMENSIONS ARE IN MILLIMETERS

8. Application Notes

Title	Description	Doc
Command Reference Manual	Description of all commands	32001539_Command_Reference.pdf
PCB Layout Guidelines	Hints how to make for a good RF design	AN_RF_001.pdf

9. Regulatory Approvals

Doc	Title	Description
-	Declaration of Conformity	Declaration of the conformity with the essential requirements of the European Directive 2014/53/EU

10. Revision History

Revision	Date	Description
0.0	30.05.2022	First release